

QuickCap[®] NX

QuickCap NX is the next-generation 3D parasitic extractor for critical circuit analysis. QuickCap NX is built on QuickCap, the gold standard for extraction, and includes key capabilities that allow the tool to address design challenges that occur in 90-nm and smaller process technologies. With advanced new process modeling, technology model encryption, a parallel execution mode, reference-level SPICE netlist generation and reduction, and a new 3D graphics viewer, users can shorten the design cycle by more accurately predicting silicon performance.

- Built on QuickCap, the industry's gold-standard reference for accurate parasitic capacitance.
- Unique random-walk algorithm offers self-capacitance, coupling capacitance and distributed capacitance extraction for test structures and for design blocks and full-chip critical nets.
- Supports advanced process modeling of complex geometries and process effects for accurate analysis of nanometer designs.
- Technology file encryption provides foundries with a secure method of sharing process information.
- Supports critical circuit analysis with network reductions using user-specified accuracy requirements, resulting in faster SPICE simulations.
- Faster runtime enabled by parallel processing, tiling, bounded nets and hierarchical extraction allows analysis of large designs.
- 3D graphical viewer eases debugging of the results and process technology files.

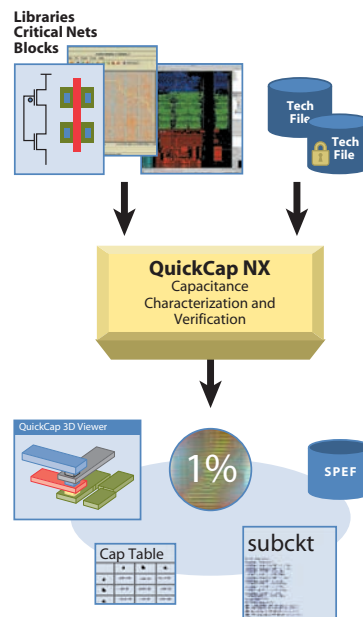

As geometries shrink and clock frequencies increase, designers need more accurate parasitic values to adequately predict timing and noise to avoid excessive design margins and failed chips. The growing need for more accuracy makes it increasingly necessary to account for precise fringing electrostatic fields and process effects in test structures and analyzing critical cells, blocks and nets. Conventional 3D field solvers don't provide robust, consistent, accurate capacitance values for actual designs, nor do they have sufficient capacity to handle moderately sized blocks or long critical nets.

QuickCap NX is an accurate 3D extractor that precisely models advanced process effects. Its capabilities are built on QuickCap, which is in production use in the Top 10 semiconductor companies as the golden reference tool for parasitic extraction. With better process models, QuickCap NX users can perform accurate noise and timing analysis and achieve design closure faster. It is used in process studies, characterization and correlation involving 90- and 65-nanometer (nm) processes, and to support highly accurate device-level SPICE simulations.

QuickCap™ NX

QuickCap NX includes important new capabilities. Technology file encryption provides foundries with a secure method of sharing additional process information with their customers, allowing them to further enhance the accuracy of their parasitic extraction. Parallel operation and hierarchical processing significantly improve runtime. A powerful 3D graphics viewer simplifies and accelerates the debug of new complex circuit structures and technology files.

Powerful Geometry Processing Engine

The geometry pre-processor gds2cap translates the 2D layout data into a 3D representation and reduced SPICE netlist with resistance and capacitance. The program gds2cap includes a powerful and versatile polygon-processing engine that handles multiple conformal dielectrics, non-Manhattan geometries, non-planar metals, metal fill, process effects (OPC, CMP, Trapezoidal wire), device recognition, resistance extraction and exclusion of device capacitances. QuickCap NX takes the 3D representation and the netlist output from gds2cap and produces an output file containing self and coupling-capacitance values and replaces the capacitance values in the netlist with accurately computed values from QuickCap NX.

Accurate Parasitic Capacitance Extraction

QuickCap NX is a highly accurate extractor, proven to closely correlate to exact analytical solutions and silicon measurements. It delivers capacitance values that are within 1 percent of silicon measurements. QuickCap NX is the only extractor that provides dial-in accuracy and error-bounds reporting on each net, giving the user complete control and trust in the accuracy of results.

QuickCap NX models advanced optical and copper effects and in-die process variations. Leading foundries have validated QuickCap NX's ability to more closely match silicon measurements. By taking process effects into account, the average difference between QuickCap NX capacitance values and actual silicon measurements has been reduced from 9.79 percent to just 0.11 percent.

Handling Large Layouts

QuickCap NX provides multiple techniques to enable critical net analysis in designs too large to fit in memory. Runtime or memory use can be reduced by using tiling, bounded nets, hierarchical processing, parallel processing or a combination of these techniques.

Leveraging QuickCap NX in the Magma Flow

QuickCap can be used for post-layout analysis in the Magma flow. QuickCap technology is also incorporated into Blast Fusion® to support high accuracy timing and noise analysis during the chip implementation flow. It is used to compute the highly accurate capacitance rules used within Blast Fusion and Quartz™ RC.

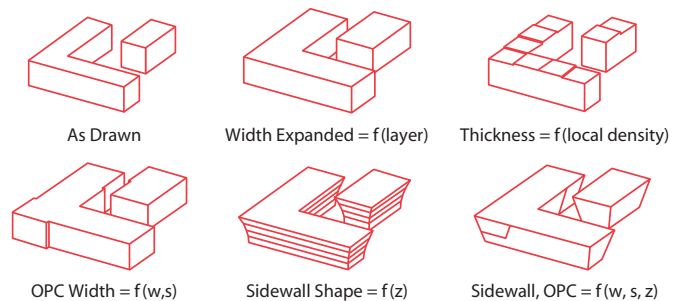

QuickCap NX accurately models advanced process effects.

TECHNOLOGY FEATURES:

- Accurate extraction of self-coupling and distributed capacitance
- Dial-in accuracy and error bounds reporting for each net
- Low memory usage independent of accuracy
- Runtime independent of net length
- Robust and accurate handling of complex geometries including non-Manhattan structures, conformal dielectrics and floating metal
- Advanced process effects for in-die process variation, optical and copper effects
- Exclusion of device capacitance and optional inclusion of device fringe capacitance
- RC reduction
- Flat and hierarchical processing
- Tile or bounded net analysis
- Parallel execution
- Technology file encryption
- 3D graphics viewer

Input

- GDSII or scripted text

Output

- Back annotated SPICE netlist
- Capacitance summary in a matrix

Platforms

- 64 bit Solaris and Linux



1650 Technology Drive, San Jose, CA 95110 USA | Tel: 408-565-7500 | Fax: 408-565-7501 | www.magma-da.com